



5/16" BORE ACCESSORIES



CB-0595

Clevis Bracket
Material: steel, bright zinc plated

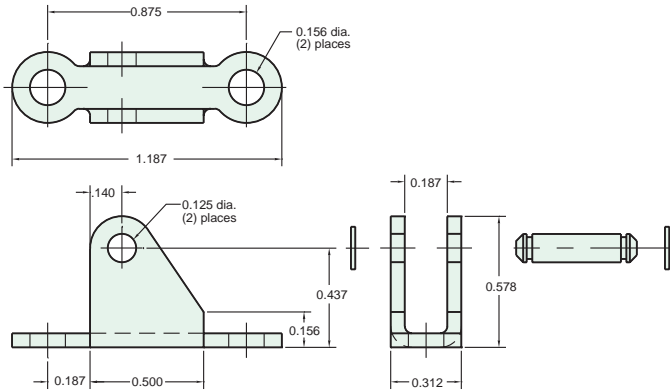

RC-0581

Rod Clevis
Material: steel, bright zinc plated

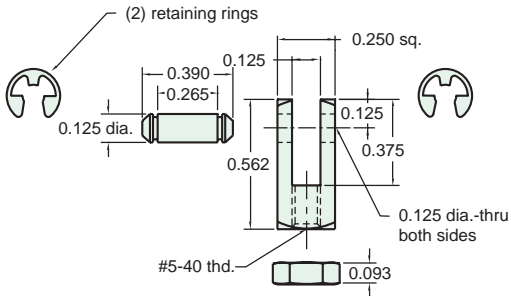

FB-0591

Foot Bracket
Material: steel, bright zinc plated

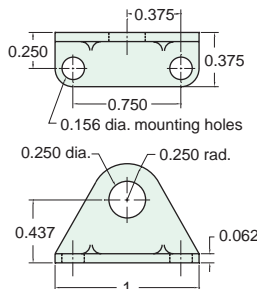

MOUNTING NUTS

Stud Nut

Part Number	Across Flats	Nut Thickness	Nut (Thread)
N04-28A	7/16"	5/32"	1/4-28
N04-28B	3/8"	1/8"	1/4-28
N06-24A	9/16"	7/32"	3/8-24
N06-24B	1/2"	1/8"	3/8-24

Rod Nut

Part Number	Across Flats	Nut Thickness	Nut (Thread)
N02-40	1/4"	3/32"	#5-40

RE-0585

Rod End
Material: steel, bright zinc plated body

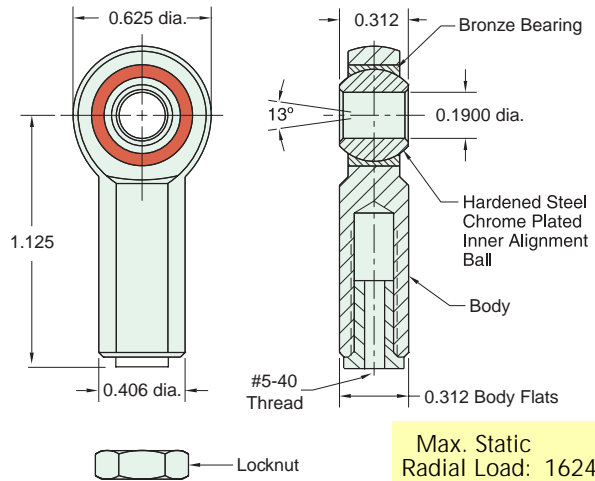

Max. Static Radial Load: 1624 lbs.
Fits Rod Thread Size: #5-40

FB-0592

Foot Bracket
Material: steel, bright zinc plated

